



PTA0157

Android Point of Sale System

Table of Contents

1. Safety Precautions	1
2. Initial Installation	2
3. Product Measurement	4
PTA0157 Single Screen.....	4
PTA0157 Dual Screen	5
4. Product Appearance	6
Single Screen.....	6
Dual Screen.....	7
6. Second Display Specifications	8
13.3" LED display specifications.....	8
15.6" LED display specifications.....	8
7. Main Board Ports	9
Appendix: Names of toxic and harmful substances or elements and their contents	10

1. Safety Precautions

1. Please place the machine on a flat vibration free surface.
2. Please make sure to avoid direct sunlight, water and other elements from entering the machine.
3. Please keep away from any strong electronic interference.
4. Do not cover the machine.
5. In areas with unstable power supply, please connect an external UPS or power source to ensure electronic stability.
6. The product comes standard with a power connector with earth leakage. Please do not change the connector unless certain of the power requirements.
7. Make sure that the ground wire of the wall socket is connected. If the ground is not connected it may cause electronic shock and even cause a fire.
8. The machine should not share the same power socket with any high-powered electronic appliances. Please ensure that all the machine has a dedicated wall socket for operation.
9. The machine will be connected to various other peripherals. Ensure that the cable and connectors are well insulated and that all screws are tightened well.
10. To clean the machine, use a damp cloth and refrain from using corrosive chemicals that might damage the machine.
11. Should operation fail on the machine, remove the machine from live power. Refrain from opening or repairing the machine. Contact an authorized repair center or person to assist with repairs.

"WARNING": For the non-compliance with the above issues, as well as non-qualified service personnel or the use of non-designated by the Company to provide and repair parts for maintenance of all the consequences, the Company does not assume any responsibility.

2. Initial Installation

1. Unpacking

Immediately after receiving the machine, unpack and check for any damage. In case of damage, the shipping company shall be informed immediately report the claim to the manufacturer. After unpacking also check the that the spare parts are complete.

2. Preparing for Installation

Examine the case for cleanliness, Logos, marks and insure labeling is correct.

Check the working environment: Because the POS is a precision instrument, the working environment should be checked and make sure it is suitable for the cash register. If the work environment is not sufficient, please do not make use of the POS.

3. The main technical specifications

Power supply voltage:

220VAC~ ± 15%

Power: 80W ± 15%

Frequency: 50–60Hz

Operating Temperature:

0 °C ~ 40 °C

Storage: -20 °C ~ +55 °C

Relative humidity:

20% ~ 93% (40 °C)

4. Preparing for use

1) Place the machine on a flat surface and ensure that the cabling is neat and sufficient. Insert the power connector in the appropriate socket.

2) Power on the machine (note: stable power source and ground is important).

3) Android OS is installed by default on the POS unit.

Main technical specifications

Main board configuration	
Processor (CPU)	RK3568 Quad-core A55 2.0GHz
System Memory (RAM)	2G
Storage Device (Flash)	8G
Display	
Size	15.6"
Resolution:	1920*1080
I/O port	
USB port	6pcs
LAN port	1pcs
COM	1pcs DB9+1pcs RJ45
RJ12 Cash Drawer	1pcs
DC IN	1x DC 12V
TF Card	1pcs
Audio	1pcs
Environmental	
Working temperature	0-50°C
Humidity	20-90%
Operating system	Android 11

3. Product Measurement

PTA0157 Single Screen

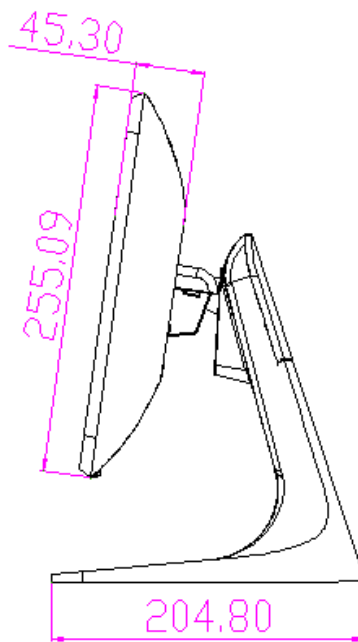
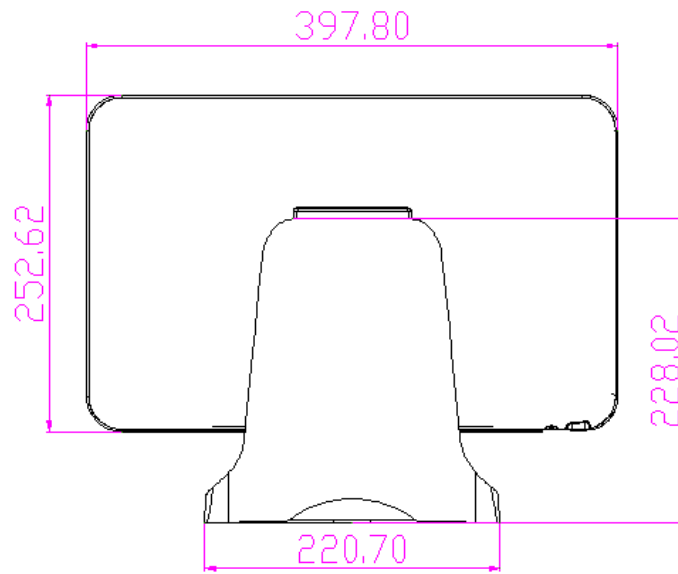

PTA0157 Dual Screen

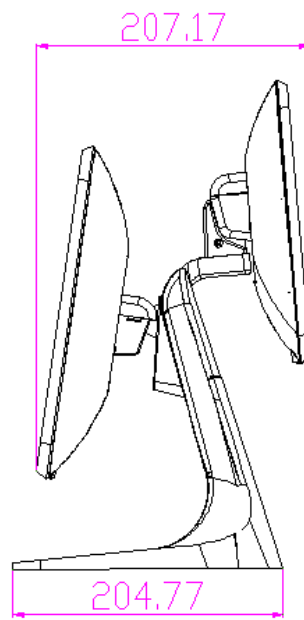
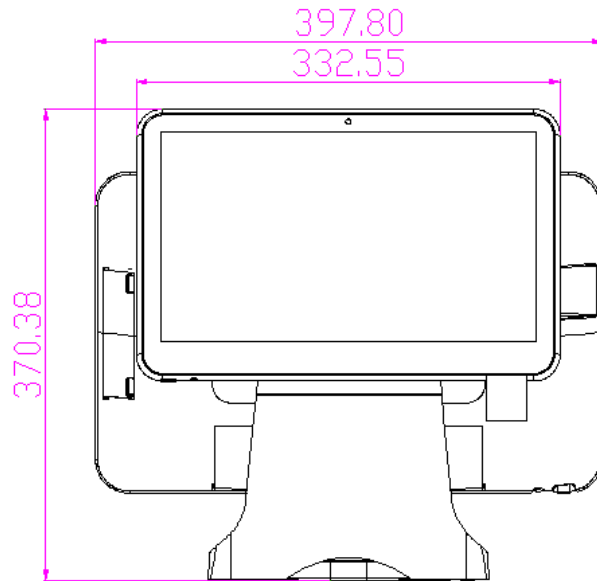

4. Product Appearance

Single Screen

Front

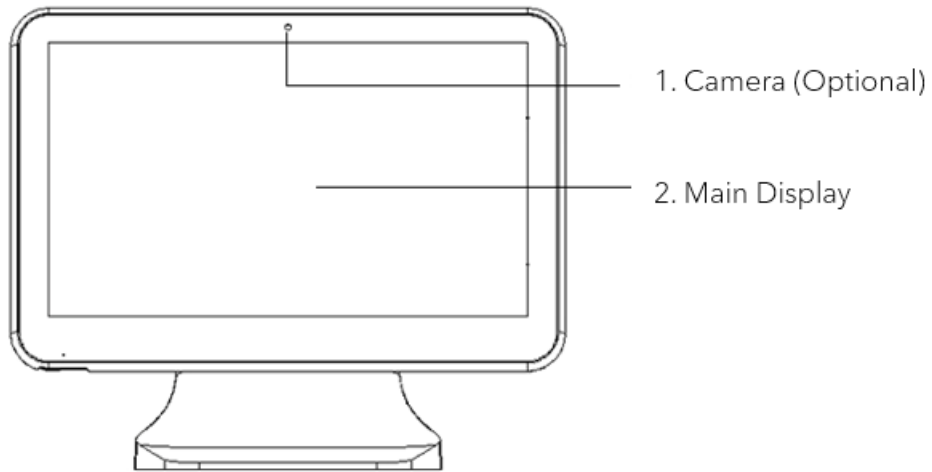

Back

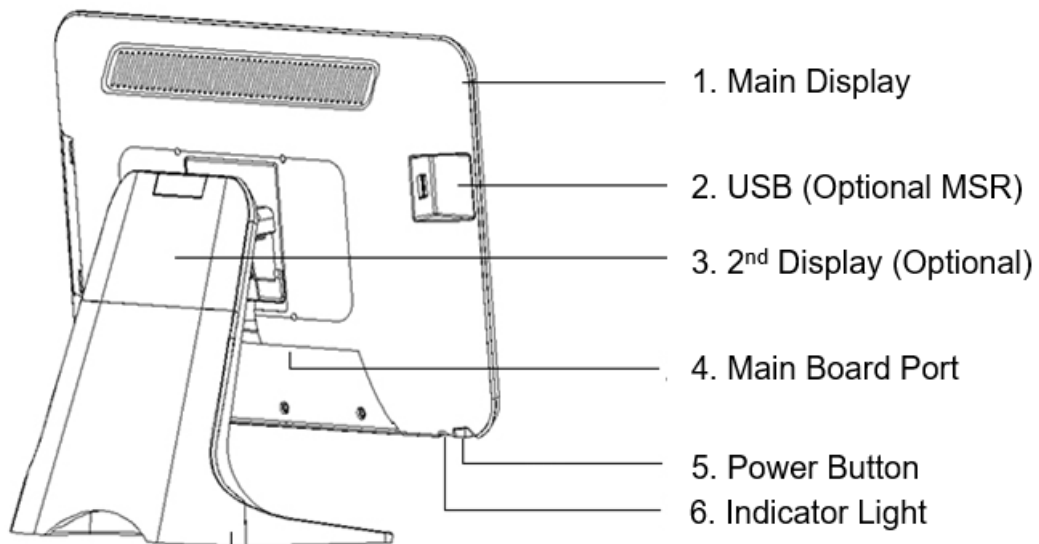

Dual Screen

Front

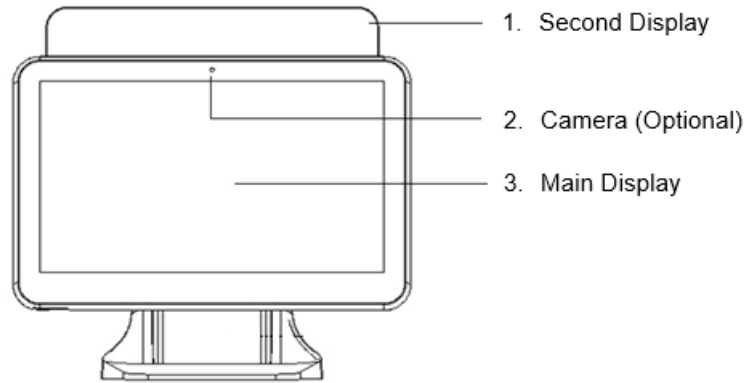

Back

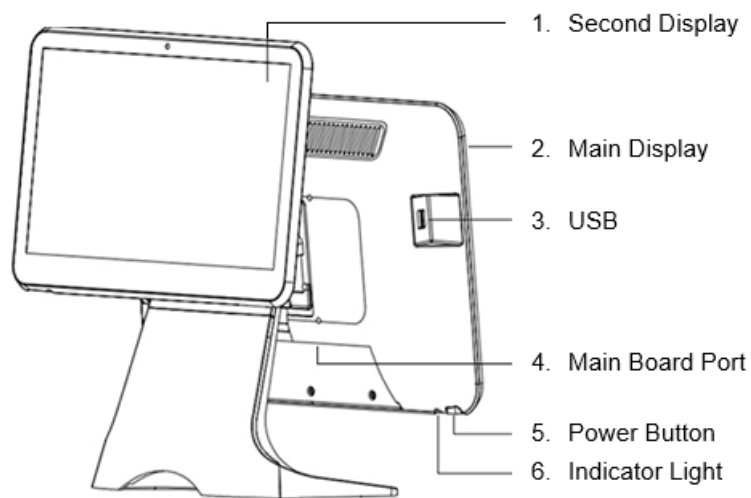

6. Second Display Specifications

13.3" LED display specifications

Item	Specification	Unit
Screen Diagonal	13.3	Inch
Active Area	293.76(H)×165.24(V)	mm
Pixel Pitch	0.153(H)×0.153(V)	mm
Resolution	1920×1080	-
Pixel Arrangement	R.G.B. Vertical stripe	-
Display Mode	Normally Black	-
White Luminance	220(Typ)	cd/m ²
Contrast Ratio	1000:1(Typ)700:1(Min)	-
Viewing angle range	89(Typ)	Deg.
Response Time	25	ms
Operating Voltage	3.3V	V
Surface Treatment	Anti-glare (3H)	-
Outline Dimension	305.2(W)×187.9(V)×2.6(D)Typ.	mm
Input signal	EDP	-
Support Colors	16,777,216	-

15.6" LED display specifications

Item	Specification	Unit
Screen Diagonal	15.6	Inch
Active Area	344.16(H)×193.59(V)	mm
Pixel Pitch	0.17925(H)×0.17925(V)	mm
Resolution	1920×1080	-
Pixel Arrangement	R.G.B. Vertical stripe	-
Display Mode	Normally White	-
White Luminance	220(Typ)	cd/m ²
Contrast Ratio	500:1(Typ)400:1(Min)	-
Viewing angle range	45(Typ)	Deg.
Response Time	16	ms
Operating Voltage	3.3V	V
Surface Treatment	Anti-glare	-
Outline Dimension	359.5(W)×206.5(V)×3.2(D)Typ.	mm
Input signal	EDP	-
Display Colors	6bit +Hi-FRC	-

7. Main Board Ports

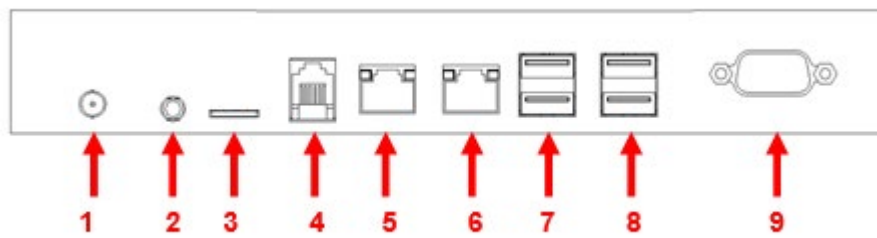
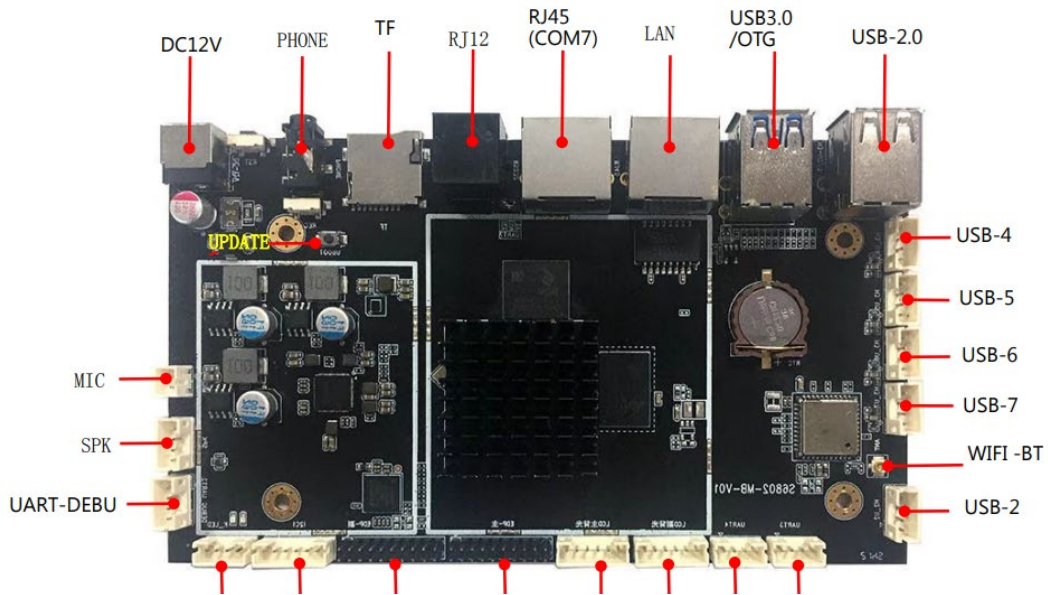

No.	Description
1	DC IN (Power input)
2	Audio (Audio input)
3	TF (TF card)
4	RJ12 (Cash drawer port)
5	RJ45 (COM port)
6	LAN (LAN port)
7	USB
8	USB
9	COM

Appendix: Names of toxic and harmful substances or elements and their contents

Part	Hazardous substance					
	Pb	Hg	Cd	Cr(VI)	PBB	PBDE
External device	x	x	o	o	o	o
Cable part	x	o	o	o	o	o
Switching power supply	x	x	o	o	o	o
Mainboard and PCBA	x	o	o	o	o	o
Memory	x	o	o	o	o	o
HDD/SSD	x	o	o	o	o	o
FAN	x	x	o	o	o	o
Plastic part	o	o	o	o	o	o
Aluminum alloy	x	o	o	x	o	o

o: Said the content of toxic and harmful substances in all homogeneous materials in the parts are specified in the SJ/T 113632006 limited the following requirements.

x: Said the content of toxic and harmful substances in at least one of the homogeneous materials beyond the limitation of SJ/T11363 - 2006 provisions; on the table in the "X" components, due to technical reasons at present cannot achieve the replacement, follow-up will gradually improve.

Note: the peripheral component contains the keyboard, display, printer, cash drawer, adapter, customer display, laser gun or scanner.



Warm Tips:

3nStar does not provide any data restoration and the backup service. The company is not responsible for damage or loss of data, programs, or storage media. Please make sure you are in time to backup any information or programs that you consider valuable. Thank you for your cooperation!